

TO: Tri Star Local Superintendents

RE: Advisory Council Referral Items for Local Boards of Education to Approve/Disapprove

FR: Tim Buschur and Tri Star Advisory Council Members

Council Meeting Date: 12/8/22

Explanation of Referral Item: A 2022 Torohmate CNC Plasma Table. Replaces old technology and will assist students with industry credentials, welding and engineering classes. Engineering classes will use. Funds will come from donating donated funds from the Civic Foundation cost \$45,092.09

This section is to be completed by local superintendent

1. Date of local board meeting that above item was acted upon: ____/____/____

2. Local board action: ____ Approved ____ Disapproved

3. Local board comments: _____

Local Superintendent Signature Date

Return this completed form to:

Tim Buschur - Tri Star
585 E Livingston
Celina OH 45822



**Cutting
Systems**

2022 TORCHMATE® 4400 | 4800 | 4510 CNC PLASMA TABLE PROPOSAL

Prepared By: Keith DeMartini

775-850-0105 / kdemartini@torchmate.com

Prepared For: Tri Star Career Compact

Cust Email:

Quote #:

Date: 10/11/2022

Cust Phone #:

Distributor: Direct

TSR:

2022 Torchmate 4000 Series

The Torchmate® 4000 series CNC plasma cutting systems by Lincoln Electric® are single source engineered plasma cutting tables developed to deliver exceptional repeatability, accuracy, and precise speed. Rapid delivery and setup time will get your machine up and running quickly. Our industry-leading support and low operational costs ensure you spend more time cutting projects and limiting business downtime. The Torchmate 4000 Series plasma tables are available as 4x4, 4x8, and 5x10 plasma cutting tables, with model numbers 4400, 4800, and 4510, respectively.

The Torchmate plasma cutting machines are available in multiple configurations and include all of the components needed to operate the system, including an integrated touchscreen HMI, height control, magnetic torch breakaway, plasma power supply, laser pointer, and water table.

The largest machine in the line, the Torchmate 4510, is a machine that gives you a 5' x 10' plasma cutting table able to support a 5' x 10' sheet of steel, giving you 36% more material capacity than a 4800, allowing you to spend more time cutting and less time changing sheets. This allows you to cut larger single piece sheets to expand the capabilities of your shop for all types of jobs. All three table models now support optional 1" thick A36 mild steel at maximum advertised cutting dimensions.

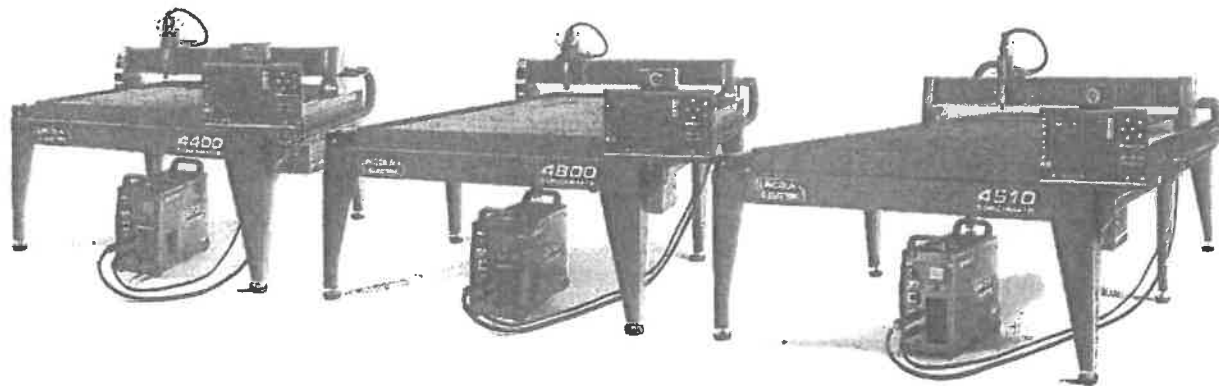

NOTICE: THIS PROPOSAL IS CONTINGENT ON A LACK OF IMPACT BY THE CORONAVIRUS NATIONAL EMERGENCY. Given the existence of the coronavirus pandemic, Lincoln Electric Cutting Systems will use its best efforts to manufacture, staff and service this project to meet the scheduled delivery date(s). However, Lincoln Electric Cutting Systems reserves its right to seek an excusable extension of time if Lincoln Electric Cutting Systems or its subcontractors or suppliers are unable to meet their contractual obligations due to the illness, supply shortages or governmental restraints on business, travel and/or assembly. To the extent that the project is suspended, Lincoln Electric Cutting Systems reserves its right to seek additional costs associated with the suspension.

Finance your investment
starting at

\$545.75

per month o.a.c.

Quote #:

Date: 10/11/2022

**Cutting
Systems**

Quote Valid for 30 Days

MACHINE	POWER SUPPLY	PRODUCT NUMBER	QTY	PRICE
Torchmate 4400 [4'x4'] CNC Plasma Cutting System	Flexcut 80 Amp, 3/4" Pierce ✓	LECS-080-4510-00	1	\$39,499.00
Torchmate 4800 [4'x8'] CNC Plasma Cutting System	Flexcut 125 Amp, 1" Pierce			
Torchmate 4510 [5'x10'] CNC Plasma Cutting System ✓		Single or Three phase power, 50/60hz, 208-575vAC		
MACHINE TOTAL				\$ 39,499.00
ACCESSORIES, CONSUMABLES AND SOFTWARE OPTIONS	PRODUCT NUMBER	QTY	PRICE	
4000 TC Tube & Pipe Cutter	LECS-080-4XTC-00		\$19,999.00	
Lincoln Electric PlateGuard™ Water Table Additive (5 Gallons)	TMS-310-0001-00	3	\$623.04	
Pneumatic Plate Marking Tool (Assembly required)	TMS-203-1000-24		\$2,902.78	
Optional Handheld Plasma Torch 25 ft - FC80 Only	K2849-1		\$1,099.00	
Flexcut Consumable Starter Kit	TMS-010-0001-17		\$1,000.00	
TMCAD Design Upgrade: Nesting and Vectorizing	TMS-106-0011-11		\$585.26	
TMCAD ART Upgrade: ProText, Art Files, Fonts, Text Manipulation	TMS-106-0011-04		\$626.32	
TMCAD Education: Unlimited Student Licenses + Design & Art upgrades	TMS-106-0011-19	1	\$1,421.05	
TMCAD Additional License Dongle	TMS-106-0011-18		\$162.82	
Two Stage Air filtration, moisture separation and dryer assembly	TMS-214-0000-00		\$610.93	
Accessories Total				\$ 2,044.09
TRAINING OPTIONS	PRODUCT NUMBER	QTY	PRICE	
Torchmate Success Package Gold	TMS-010-0001-16		\$2,250.00	
TMCAD Basic Project Book Classroom Series	TMS-106-0010-10		\$52.58	
Torchmate Academy, 4000 Series Online Learning Portal	TMS-010-0001-06	1	\$750.00	
4000 Series Virtual Training. Two, 4 hour blocks	TMS-010-0001-10		\$750.00	
Basic Onsite Training, 2 Days	TMS-010-0003-02		\$5,250.00	
Advanced Onsite Training, 3 Days	TMS-010-0003-03		\$6,750.00	
Three Day Lincoln Electric Classroom Training. Reno NV, or Cleveland OH	TMS-010-0002-01		\$1,000.00	
Training Total				\$ 750.00
CUSTOMER CONTACT INFORMATION:				
CUSTOMER NAME Tri Star Career Compact			Subtotal	\$ 42,293.09
CONTACT NUMBER			Shipping Total	\$ 2,800.00
EMAIL			Tax	
SHIPPING ADDRESS				
REQUESTED SHIPPING DATE				
FOB Reno to Hawaii Alaska International FOB S.F.	Mileage			
PO #	Date			
Card Holder	CW			
Billing Address				
Phone Number	Grand Total \$ 45,093.09			
Sales Associate Keith DeMartini				
TSR				
Distributor Direct				
Distributor Contact				
I have been made aware of my Training Options, Plasma Cutter Power Requirements, Shipping/Unloading Requirements, Site Prep Guide and Terms and Conditions.				
Customer Signature				

This quote is valid for 30 days, and is governed by Seller's Terms and Conditions of Sale attached hereto and/or located at the website indicated below. Any reference to Buyer's request for quote incorporates only the technical information described therein. ALL TERMS AND CONDITIONS IN BUYER'S REQUEST FOR PROPOSAL/QUOTE ARE DEEMED MATERIAL ALTERATIONS AND ARE HEREBY EXPRESSLY REJECTED. Seller's Website: <https://torchmate.com/terms-and-conditions>

CHOOSE YOUR CONFIGURATION

4400 TABLE

The Torchmate 4400 is a powerful and fully assembled CNC Plasma cutting table. Designed to begin cutting immediately, this robust machine contains production grade components to deliver consistent cuts every time. This high-end cutting table has a small footprint and can easily fit into any small-to-medium sized fabrication shops. All that is required to begin cutting is compressed air, power, dedicated ground rod, and water. The water table fume extraction, slat supports, computer, CAD Software, CNC controller, height control, and magnetic torch breakaway are included in the base price.

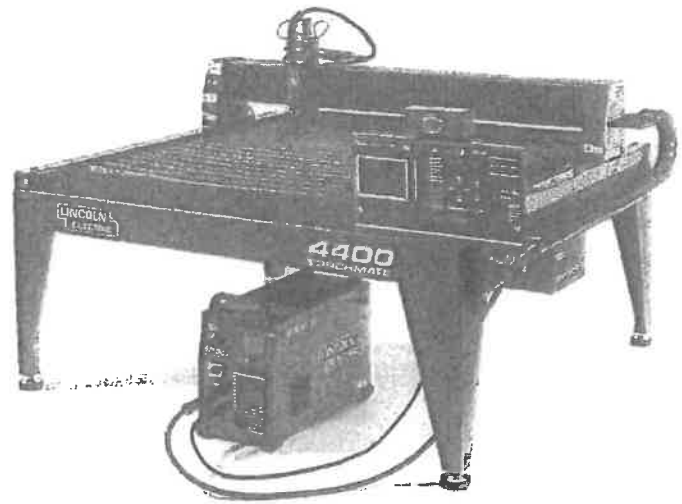

4800 TABLE

Designed for growing businesses, the Torchmate 4800 is the ideal cutting machine. Within minutes of uncrating, the fully assembled Torchmate 4800 machine will be ready for any job. With a longer cutting area, additional shearing fees and costs can be avoided. Lincoln Electric engineers have performed extensive tests to ensure that the table will consistently cut the same quality, regardless of where the material is positioned.

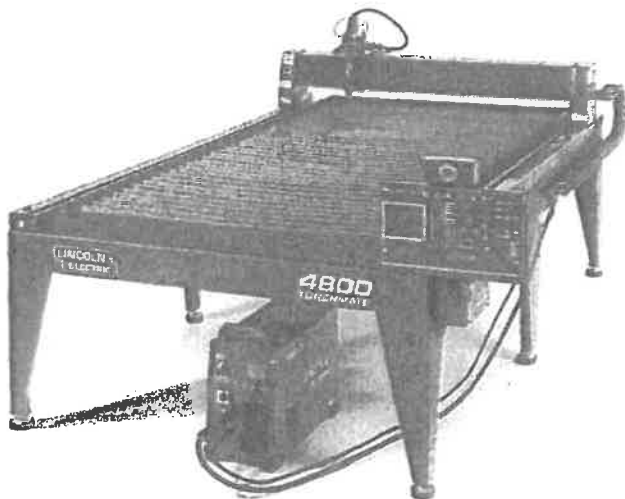

4510 TABLE

Like the other 4x00 machines, the Torchmate 4510 is fully assembled and made to begin cutting in less than an hour after being delivered. This machine has the largest cutting area of all the 4x00 tables. With a 5'x10' cutting area, the Torchmate 4510 has 36% more material capacity than the Torchmate 4800. This machine was designed to save you time and money while providing the same great benefits the Torchmate 4400 and 4800 offer.

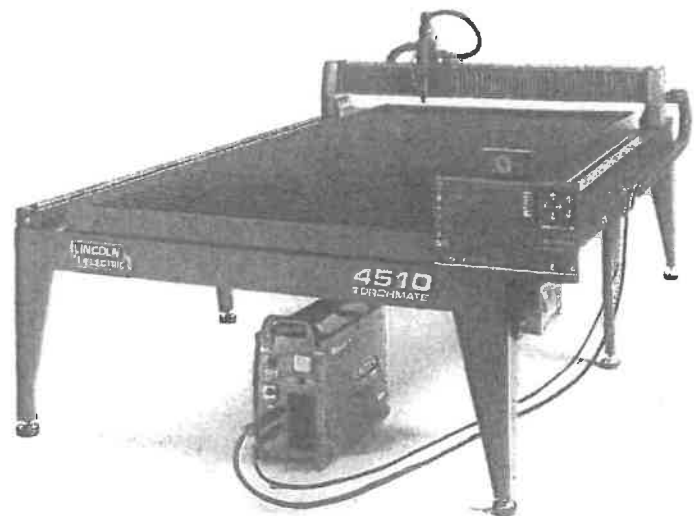

CHOOSE YOUR POWER SUPPLY



FLEXCUT® 80

80 Amp Plasma

3/4" CUT CAPACITY (MILD STEEL)

The FlexCut 80 is a constant current, plasma cutting power source that delivers faster cut speeds, optimal cut performance, and durability. The Flexcut 80 provides unparalleled plasma cutting efficiency.



FLEXCUT® 125

125 Amp Plasma

1.0" CUT CAPACITY (MILD STEEL)

The FlexCut 125 is the industry's first conventional air plasma cutter equipped with plasma marking. The powerful mechanized plasma cutter provides exceptional pierce and cut capabilities.

CHOOSE YOUR ACCESSORIES

HAND-HELD PLASMA TORCH

The hand-held plasma torch allows for precise and fast material cutting. It includes a 25ft or 50 ft torch cable and one set of all required torch expendable parts.

(For FlexCut 80 Plasma only)

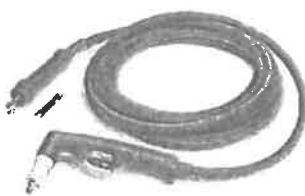

TWO STAGE AIR FILTER ASSEMBLY

Extend the life of your consumables and protect your plasma cutter from harmful particulates and moisture from the compressed air source. This easy to install assembly filters particulates down to 5 microns, and dries the air with a moisture separator and desiccant drier stage.



PLATEGUARD WATER TABLE ADDITIVE

Prevent surface corrosion on steel plate loaded on the table, and extend the life of your machine bed by adding Lincoln Electric's recommended concentrated Plateguard solution.



PNEUMATIC PLATE MARKER

The Plate Marker Accessory is a pneumatic oscillating engraving tool that allows for high-precision markings and details on a wide range of metals.

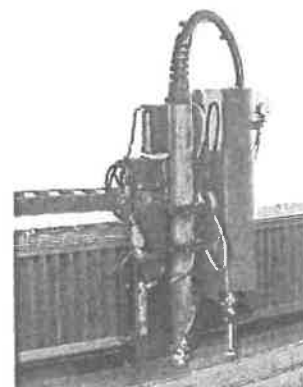

4000 TC PIPE & TUBE CUTTER

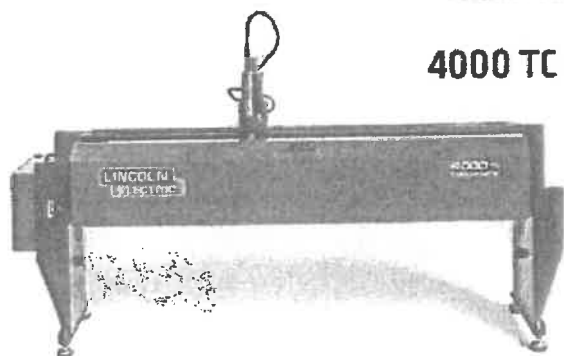

The two-axis tube cutter is capable of cutting and profiling schedule 40 pipe with an outside diameter of 1.5 to 6 inches and a machine cutting envelope of 84 inches. It easily connects to the 4x00 series tables with cable connections. The 2 inch through chuck offers motorized bevel cutting up to a 45° cut angle for weld coupons.

CHOOSE YOUR SOFTWARE

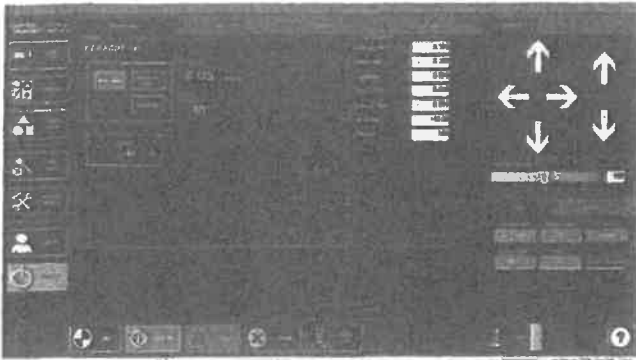

Torchmate VMD/Nest (Included with 4000 Series Plate Machines)

Torchmate Visual Machine Designer (VMD) is the human-machine interface (HMI) to the Torchmate 4000 Series CNC Machines. VMD automatically programs cut parameters for the most common materials into the G-Code file, such as Feedrate, Pierce Height, and Cut Height. VMDnest provides the machine operator with onboard single-sheet nesting capabilities. Bring multiple DXF or DWG's directly to the machine from your CAD software and have the operator nest them to a sheet, no offline software required.

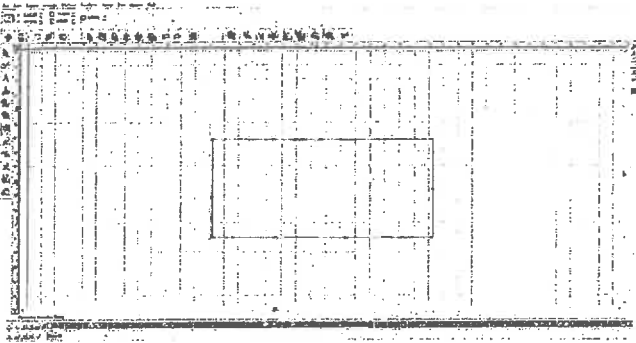

Torchmate CAD/CAM Design (Included with 4000 Series Plate Machines)

Torchmate CAD offers versatile drawing features including shape creating, importation of other file types such as DXF, tracing of scanned images, and text design. The user-friendly interface allows both new and experienced users to design any part imaginable from simple tabs and brackets to intricate signs and art scenes. Torchmate CAM compensates for the cut width (kerf) of the plasma arc to ensure that a part is cut as accurately as it was drawn. Torchmate CAD/CAM software is supported by Torchmate with a selection of digital training options.

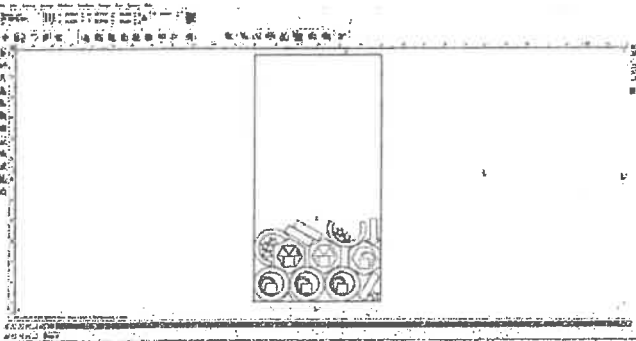

Torchmate CAD/CAM Design Upgrade

Includes Offline Nesting, a vectorization tool and Advanced Shape Library. Offline Nesting minimizes the amount of scrap material produced during cutting using an efficient algorithm to place many components tightly together leaving minimal material waste. The vectorization tool allows you to convert image files into editable CAD drawings. The off-line shape library give you 89 preselected common shapes that can be edited to fit your needs.

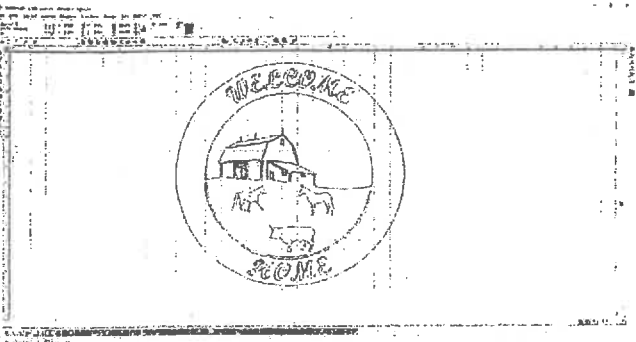

Torchmate CAD ART Upgrade

This upgrade gives you 1,400 fonts to choose from and allows them to accurately fit the text to an arc or any other shape in the cutting area automatically. There are hundreds of silhouette images that are suitable for plasma cutting. These are time-saving upgrades that can be worth while for businesses that heavily use the text tool. (TM CAD/CAM Design & upgrade required)

CHOOSE YOUR TRAINING PACKAGE

Torchmate 4000 Series Success Packages

Torchmate Success Packages are the best way for you to get up and running successfully with your new Torchmate machine in as little time as possible. The packages offer training options that fit your needs - from Virtual Group Training in our Bronze Package, all the way to our onsite training option included in our Gold package. By choosing one of these packages you will be able to operate your machine with confidence and be able to rapidly integrate the machine into your day to day operation.

BRONZE

\$750

• Torchmate Academy online training - 1 one year subscription. (\$750 account credit if completed within 30 days)

• Direct FlexCut consumables discount (15% for 1 year)

GOLD

\$2,250

• Torchmate Academy online training - 1 one year subscription. (\$750 account credit if completed within 30 days)

• 3 day Torchmate training at Lincoln Electric Reno or Cleveland facility* (\$1,000 value)

• \$1,000 consumables package for FlexCut plasma cutters

• Direct FlexCut consumables discount (15% for 2 years)

SILVER

\$2,000

• Torchmate Academy online training - 1 one year subscription. (\$750 account credit if completed within 30 days)

• Torchmate LIVE virtual training - 2 four hour sessions (\$750 value)

• \$1,000 consumables package for FlexCut plasma cutters

• Direct FlexCut consumables discount (15% for 2 years)

*Travel and lodging not included

ONLINE

Torchmate Academy Machine and CAD Training

Torchmate Academy is an online-based learning platform that takes the user guide's information to a new level. It covers all of the key features and functions in more detail. Video walkthroughs and supporting documentation are provided throughout to assist you in getting the most out of your Torchmate investment.

<https://torchmate.com/academy>

- Basic Operations
- Visual Machine Designer Operation
- Maintenance and troubleshooting
- Plasma cutter and consumable overview
- Torchmate CAD Operations and Basic Training
- Importing and manipulating DXF files
- Nesting and layers
- Uses video, slides, and quizzes
- One year of access

VIRTUAL

Torchmate LIVE - Machine and CAD Training

Torchmate LIVE is an interactive training solution for individuals that cannot travel or have the time for in-house training, but need personal interaction of an on-site training. We bring the instructor to your facility via the internet. Join via ZOOM with our expert trainers to cover the machine basics and operations.

Schedule your time on our website:

www.torchmate.com/seminars

Block 1 - TM CAD (4 hours)

- Basic features and tools
- Functions of the toolbar
- Common menu items
- Shape creation
- Text usage
- Tool path creation
- Cut path output
- Nameplate project

Block 2 - Machine Operations (4 hours)

- Machine overview
- Plasma cutter and consumables
- Proper start-up
- Visual Machine Designer overview
- Cut Quality and Line Speed test
- Nameplate cut process
- Proper Shutdown
- Machine Maintenance

ONSITE

Torchmate Onsite - Machine and CAD Training

Have our expert technicians come to your facility for 1-, 2-, or 3-day machine training and servicing at your facility. The provider will cover the machine operations, proper maintenance, and software training for a flat rate.

To get a updated cost and scheduling availability, email our team:

LECSfieldservice@lincolnelectric.com

One Day

- Owner's Manual Review
- Verify all connections
- Verify factory specifications
- Perform factory acceptance test cut.
- Consumable Training
- Re-order information
- Plasma power supply operation

Second Day

- TMCAD overview and workflow
- Shape creation
- Text usage
- Tool path creation
- Cut path output
- Nameplate project
- Shape Library
- Job Set Up and Nesting
- Cut customer file
- Machine maintenance
- Acceptance sign off

Third Day

- Advanced CAD Training
- Working with Customer Files
- Additional hands-on Training

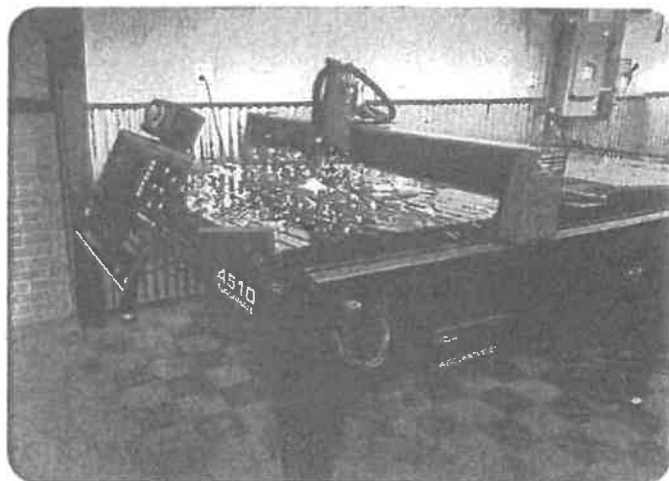

The previous scope of work defines the various options for CAD training, onsite machine commissioning, and operations training for the Torchmate 4000 series configurations. Please note that CAD training is not included in onsite machine commissioning and operations training options. Torchmate is not able to provide third-party CAD training. Any work outside the agreed scope will be billed separately for time and material via an approved Lincoln Electric Cutting Systems extra work order. Lincoln Electric Cutting Systems defines a workday as a typical 8 hour day with a 1-hour lunch break. Overtime hours requires approval.

3 DAY IN-HOUSE TORCHMATE TRAINING

Torchmate In-House

In-house training is a 3-day, hands-on project-based classroom training held in Reno & Cleveland. Learn and create real-world projects that cover the TMCAD software and its features. Take those projects and cut them out on the machine where the trainers will cover everything from cut quality to proper maintenance. Build the proper foundation to streamline your success.



3 Day Basic Torchmate Operations Training

- Introduce the CAD software
- Go over basic functions and tools
- Generate basic shapes
- Discuss WELDING and MAKE/BREAK PATH functions
- Generate NAMEPLATE project
- Generate CLIP ART project
- Import images from web and use VECTORIZATION tool
- Node Editing
- Polyarc vs. Polygon
- Generate precision part by node editing
- Discuss multispeed files and their creation
- Array, Nesting, and Badging

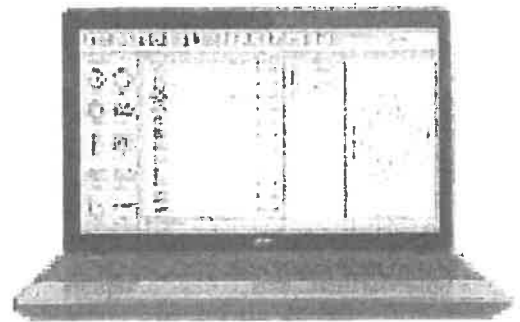

BOOK TODAY www.torchmate.com/seminars

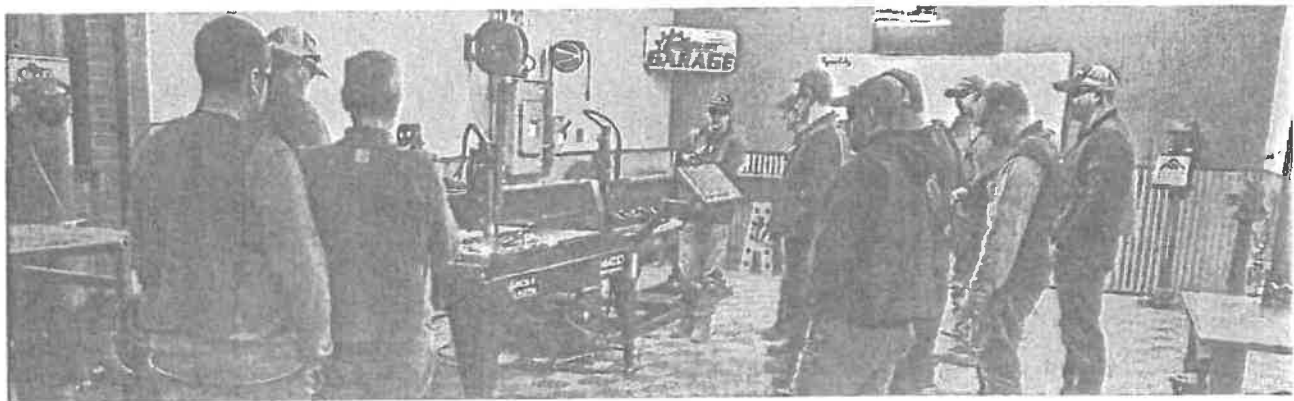

SYSTEM INCLUDES



- Complete 4x4, 4x8 or 5x10 Multiple Station Cutting Area CNC Plasma Table
- Ohmic Initial Height Sense with Automatic Torch Arc-Voltage Height Control
- Laser Pointer Attachment
- Magnetic Torch Breakaway
- Water table fume extraction
- CNC Controller
- CAD Software
- DXF & DWG Importer (use with most CAD programs)
- Industrial Touchscreen HMI
- Consumable Starter Kit
- Technical Phone Support
- 2 Year Complete System Warranty

TABLE SPECIFICATIONS

Power Requirements

- 115V / 15A Dedicated circuit
- 87-109 psi (6-75 bar) 380 SCFH 180 SLPM
- FC80 1 phase: 208,230 50/60hz or 3 phase 208,230,400,460,575 50/60hz
- FC125 3 phase: 380,400,415,460,575 50/60hz

Machine Size

- 4400 74" x 67" x 63" [As Shipped 85" x 77" x 71"]
- 4800 74" x 114" x 63" [As Shipped 122" x 77" x 71"]
- 4510 86" x 138" x 63" [As Shipped 144" x 91" x 74"]

Shipping Weight

- 4400 1,177 lbs (531 kg)
- 4800 1,615 lbs (732 kg)
- 4510 2,220 lbs (1007 kg)

See OSHA guidelines for proper forklift

Water Capacity

- 4400 60 Gallons (230 Liters)
- 4800 107 Gallons (405 Liters)
- 4510 140 Gallons (530 Liters)

Cut Speed

- Flexcut 80 1/4" [148 ipm], 1/2" [52 ipm], 3/4" [26 ipm]
- Flexcut 125 1/4" [210 ipm], 1/2" [88 ipm], 3/4" [52 ipm], 1" [32 ipm]

Plasma Pierce Capacity

- Flexcut 80 3/4" Mild Steel
- Flexcut 125 1" Mild Steel

Traverse Speed

- 500 ipm

Material Weight Capacity

- 4400 at 48" x 48" holds maximum of 652.8 lbs (40.8 lbs per square foot)
- 4800 at 48" x 96" holds maximum of 1,305.06 lbs (40.8 lbs per square foot)
- 4510 at 60" x 120" holds maximum of 2,040 lbs (40.8 lbs per square foot)

Motors

- Stepper Motors (3) 396 oz-in

Drive System

- Spring loaded Rack and Pinion

Linear Guidance

- Dual 20 mm Y axis and Dual 15mm X axis

Height Control

- Magnetic Breakaway
- Ohmic Sensing
- Automatic Torch Arc Voltage Height Control

Software

- Easy-To-Use Lincoln Electric VMD User Interface
- Onboard DXF CAM Importer with Irregular Part Nesting
- Onboard Popular Shape Library
- Offline Torchmate Cad/Cam Software

Safety

- Safety System Supporting Emergency Stop Switch
- Safety System Extended To External Peripherals
- External Drive Power On Switch

Machine Construction

- Fabricated Steel Frame with Powder Coated Finish

Warranty

- 2 Year Machine and Plasma Torch Lead Warranty
- 3 Year Plasma Power Supply Warranty

PLASMA SPECIFICATIONS



FLEXCUT® 80

3/4" CUT CAPACITY



FLEXCUT® 125

1" CUT CAPACITY

Product Name	Input Power Voltage/Phase/Hz	Rated Input Current/Voltage/Duty Cycle	Air Pressure Required	Production Cutting Capacity	
FlexCut 80	208/230/400/460/575 3PH 50/60Hz	60A/140V /100% 80A/140V /80%	87-109 PSI (6.0 - 7.5 Bar)	Mild Steel	3/4" (20 mm)
	230 1PH 50/60Hz	60A/140V /100% 80A/140V /80%		Stainless	5/8" (16 mm)
	200-208 1PH 50/60Hz	60A/140V /100% 80A/140V /80%		Aluminum	5/8" (16 mm)
FlexCut 125	308-400-415/460/575V 3PH 50/60Hz	125 A/125V /100%	90-120 PSI (6.2 - 8.2 Bar)	Mild Steel	1.0" (25mm)
				Stainless	3/4" (20 mm)
				Aluminum	1.0" (25 mm)

*Cut speeds for best quality, production results may vary.

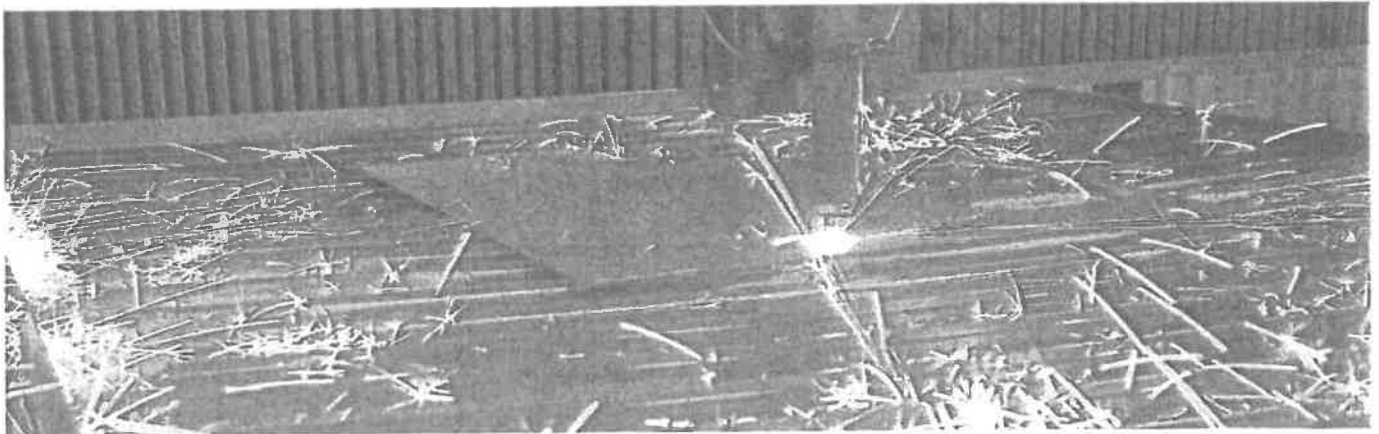

LOCATION

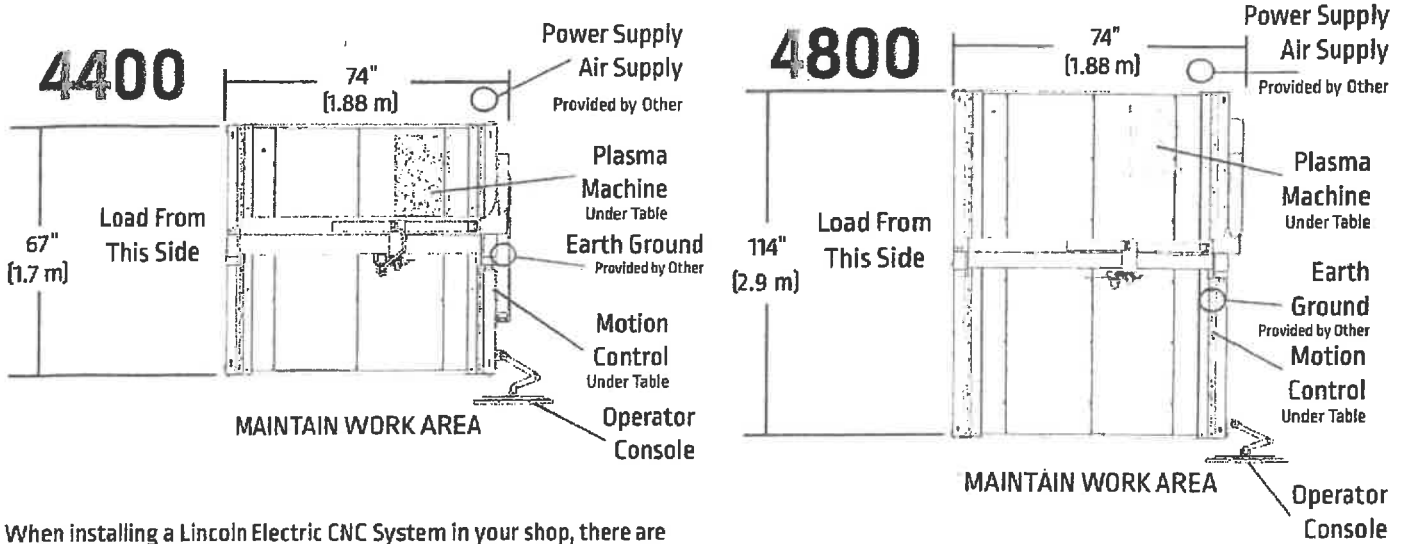

When installing a Lincoln Electric CNC System in your shop, there are many factors that will influence the potential productivity, ease of use of the machine, and the safety of the operator. The main factors to prepare for include the physical layout and placement of the machine in the shop, the availability of power, an EMI ground, compressed air and other gases, and ventilation.

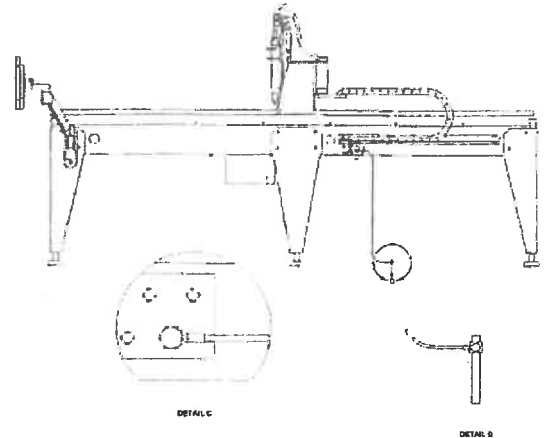
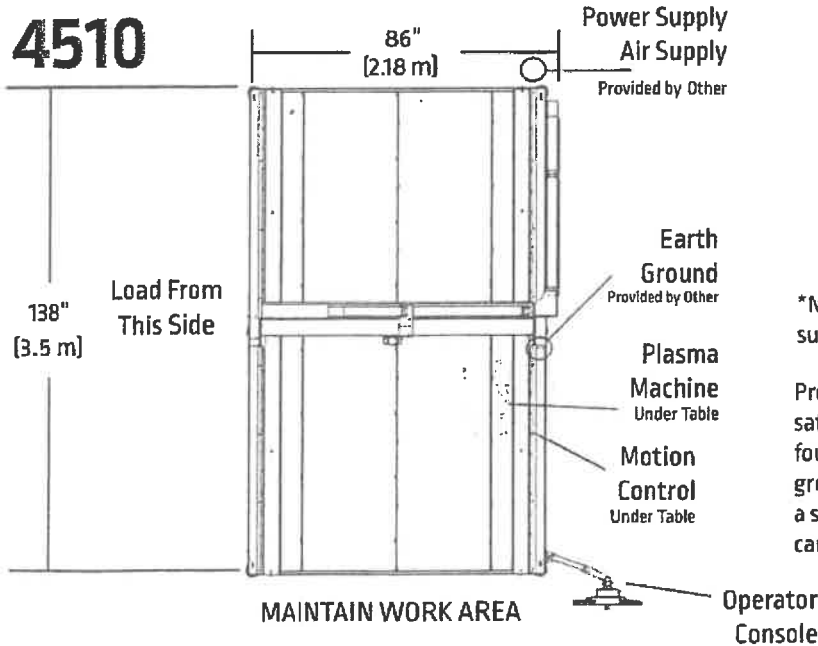

*Note: Power supply does not include a plug, must be supplied by an electrician.

Proper grounding must be provided to ensure personnel safety and to suppress high frequency noise. The foundation of good grounding is an effective earth ground rod. A star ground point connects to the rod with a short, heavy conductor. A simple copper clad steel rod can be driven into the ground to create a grounding rod.

MAINTAIN YOUR WORK AREA

- When preparing to install the Lincoln Electric CNC Cutting System, provide sufficient space. Three feet of work space should be maintained at front of machine
- Overhead Crane or forklift to load material opposite the cable carrier only. Utilize the back of the machine to park the gantry while loading material.
- A dedicated earth ground must be provided and should be installed in a manner to reduce trip hazard
- The table power leads included is limited to 10 feet.

CUSTOMER EXPERIENCE HIGHLIGHT

MOTOBILT

Motobilt focuses on providing high quality Jeep and truck accessories to 4x4 enthusiasts around the world. They utilize their Torchmate 4800 CNC plasma cutting table to cut out their metal parts.



Watch full story [\(link to YouTube\)](#)



Back Alley Metals

Back Alley Metals ships their high-quality custom metal work across the globe. With the capabilities of their Torchmate machine, they are able to create customized intricate wall art, bear boxes, and precision tools for home builders.

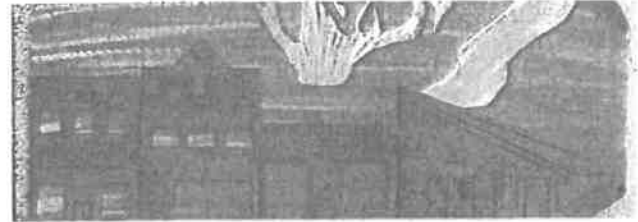

Watch full story [\(link to YouTube\)](#)

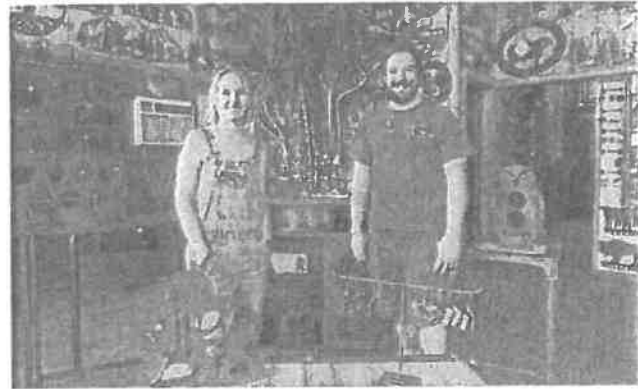

FabricationForum.com

to openly communicate and collaborate with Torchmate customers across the globe.

The [Fabrication Forum](#) is an online community of Torchmate customers where you can find tips and tricks, project ideas, troubleshooting, and general fabrication help for your torchmate machine. The forum offers an interactive platform for individuals

The forum provides a new perspective to showcase the different applications your Torchmate machine can be used for. With over a thousand discussions and members from various industries, you are sure to find your next Torchmate project to cut. Login to FabricationForum.com today to start your next project!

Learn more about our training options at www.torchmate.com/academy



To purchase consumables, please visit www.torchmatestore.com



The Lincoln Electric Company is manufacturing and selling high quality welding equipment, consumables, and cutting equipment. Our challenge is to meet the needs of our customers and to exceed their expectations. On occasion, purchasers may ask Lincoln Electric for information or advice about their use of our products. Our employees respond to inquiries to the best of their ability based on information provided to them by the customers and the knowledge they may have concerning the application. Our employees, however, are not in a position to verify the information provided or to evaluate the engineering requirements for the particular weldment. Accordingly, Lincoln Electric does not warrant or guarantee or assume any liability with respect to such information or advice. Moreover, the provision of such information or advice does not create, expand, or alter any warranty on our products. Any express or implied warranty that might arise from the information or advice, including any implied warranty of merchantability or any warranty of fitness for any customers' particular purpose is specifically disclaimed. Lincoln Electric is a responsive manufacturer, but the selection and use of specific products sold by Lincoln Electric is solely within the control of, and remains the sole responsibility of the customer. Many variables beyond the control of Lincoln Electric affect the results obtained in applying these types of fabrication methods and service requirements. Subject to Change – This information is accurate to the best of our knowledge at the time of printing. Please refer to www.lincolnelectric.com for any updated information.

 **Warning:** Cancer and Reproductive Harm - <https://www.p65warnings.ca.gov/>